

Graflex Sensor Positioner – PT90E

*The **Graflex Inc. Sensor Positioner PT90E** offers the reliability and features that allow you to rest easy at a price that gives our competition nightmares.*



PT90E Highlights

- **90 Pound Payload Capacity (Balanced)**
- **Economical Price**
- **Rugged Design**
- **No Routine Maintenance Required**
- **Excellent Resolution, Accuracy and Repeatability**
- **GUI or RS-232 / 422 Control**
- **Optional Joystick Controller**
- **Optional Side Mount and / or Over-the-Top Brackets**

GRAFLEX Incorporated



Always on Target

15855 Assembly Loop – Suite 100 - Jupiter, FL 33478 – USA

Telephone: (561)691-5959 Fax: (561)691-5983 E-mail: Sales@Graflex.com

www.GRAFLEX.com

PT90E Technical Specifications

MECHANICAL

Dimensions 10.25" (w) x 10.0" (h) x 8.0" (d)
Weight ~30 Lbs
Base Dim's ~7.5" Diameter
Base Mounting Contact Factory
Construction Aluminum and Steel
Color Anodized (black) or Painted
Payload Capacity 90 Lbs Balanced / 75 Lbs Over The Top
Drive Motor Brushed DC
Travel Range 360° Continuous @ Azimuth
 + 90° To - 90° @ Elevation (Balanced)
 + 60° To - 60° @ Elevation (Over The Top)
Tilt Limits: Electrical: Continuously Adjustable
 Software Limits via GUI

ELECTRICAL

Voltage #24Vdc (Nominal)
Power Contact Factory
Heater Optional

OPERATIONAL

Travel Velocity 24°/Sec. - .1°/Sec. (Pan)
 13°/Sec. - .1°/Sec. (Tilt)
Repeatability .088°
Resolution .044° (13 Bits)
Feedback: 11 Bit Incremental Encoder

COMMUNICATION

Interface RS-422 or RS-232 or Graflex GUI
Motor Controller Microprocessor based

OPTIONS

Coatings (Finish)
 Payload Mount
 Heaters
 Shock Mount

ENVIRONMENTAL (MIL 810E)

Operating Temperature: 501.00 Procedure II (1 Cycle @ 3 Hours Each -31.7° C and 51.7° C)
 Note: These Low Temp Ranges Require Heater Blanket (Otherwise 0-70° C)

Humidity: Contact Factory

Salt Fog: Contact Factory

Dust & Wind: Contact Factory

Vibration (514.4): Contact Factory

Shock (516.4): 5± .5g's, 11.0 ± 1.1 ms half sine wave applied in each direction of 3 mutually perpendicular axis. 10 ± 1.0 g's, 11.0 ± 1.1 ms half sine wave applied in each direction of 3 mutually perpendicular axis with Optional Shock Mount.

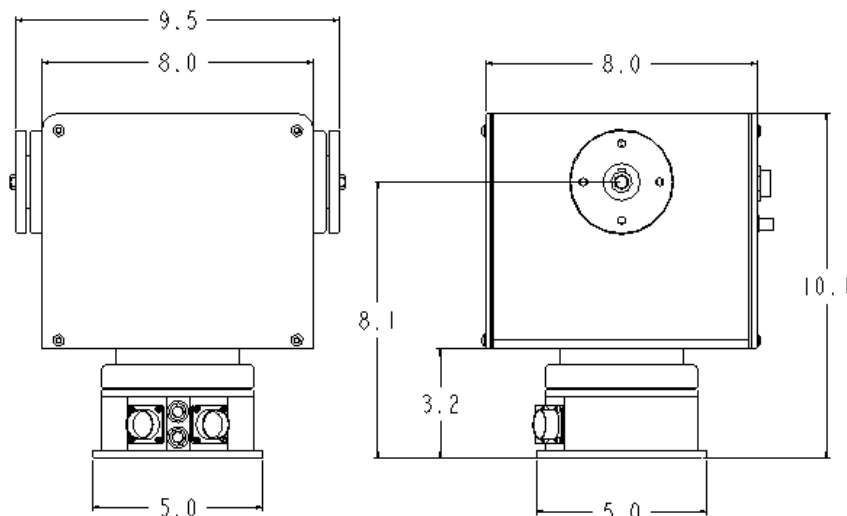

Note: Specifications are Subject to Change w/o Notification